

Mantis[®] XP

OPERATOR / PARTS MANUAL

MANTIS[®] DELUXE XP TILLER
7566



IMPORTANT!

Assembly Instructions Start on Page 7!

**Please review the Warning & Safety Information on Pages 4-6
and the Assembly Instructions before unpacking the box.**



Welcome to the World of Mantis Gardening

Here's your new MANTIS® Deluxe XP Tiller . . . the lightweight wonder that is making gardening easier.

Unlike big tillers, your MANTIS® Deluxe XP Tiller weighs only 36.3 pounds (16.5 kg) and is like no other. So it lifts easily, handles smoothly, tills and weeds precisely. And, unlike other small tillers, it features dual serpentine tines that churn soil to ten inches deep. It creates a soft, smooth seed bed, even in problem soil.

It's bigger than a mini tiller and better than a bigger tiller!

Once you know how to use your tiller correctly, we guarantee you'll love it. So first, please read this manual. It shows, step by step, how to use your tiller safely.

If you have questions about any topic in this Manual, contact your local Mantis dealer, or call 1-800-366-6268 toll free, Monday – Friday, 8:00am to 5:00pm, Eastern Time.

ATTENTION MANTIS PRODUCT OWNERS!

Get maintenance tips for your Mantis product on our web site at mantis.com



Mantis® Deluxe XP Tiller– 7566

IMPORTANT MESSAGE

Thank you for purchasing this Mantis® product from Schiller Grounds Care, Inc. You have purchased a world class product, one of the best designed and built anywhere.

This machine comes with Operation and Safety instructions, Parts and Service instructions and Engine instructions. The useful life and good service you receive from this machine depends to a large extent on how well you read and understand this manual. Treat your machine properly, lubricate and adjust it as instructed, and it will give you many years of reliable service.

Your safe use of this Mantis® product is one of our prime design objectives. Many safety features are built in, but we also rely on your good sense and care to achieve accident-free operation. For best protection, study the manual thoroughly. Learn the proper operation of all controls. Observe all safety precautions. Follow all instructions and warnings completely. Do not remove or defeat any safety features. Make sure those who operate this machine are as well informed and careful in its use as you are.

See an authorized Mantis® dealer for any service or parts needed. This service ensures that you continue to receive the best results possible from your tiller. You can trust Mantis® replacement parts because they are manufactured with the same high precision and quality as the original parts.

Schiller Grounds Care, Inc. designs and builds its equipment to serve many years in a safe and productive manner. For longest life, use this machine only as directed in the manual, keep it in good repair and follow safety warnings and instructions. You'll always be glad you did.

Schiller Grounds Care, Inc.
1028 Street Road
Southampton, PA 18966-4217
PHONE (800) 366-6268 • FAX (215) 956-3855

TABLE OF CONTENTS

	PAGE		PAGE
SAFETY RULES & WARNINGS		FUELING & STARTING	
Special Safety Information.....	4	Fueling/Oil & Starting.....	12
Safety & Warnings.....	4	Corrective Action	13
Safety Decal Information	4-5	OPERATION.....	13-16
Warning Dos or Don'ts.....	5-6	TRANSPORT	16
Engine/Fuel Warning Dos or Don'ts	6	STORAGE	17
ASSEMBLY	7	MAINTENANCE	18-20
Lower Handle	8-9	MANTIS® DELUXE XP TILLER ASSEMBLY	22-23
Kickstand	9	TROUBLESHOOTING	24
Upper Handle Assembly	10-11	EPA.....	25
Upper Handle Positioning.....	11	LIMITED WARRANTY INFORMATION ...	BACK PAGE



This Operator / Parts Manual is part of the machine. Suppliers of both new and second-hand machines must make sure that this manual is provided with the machine.

Safety Rules & Warnings

You will notice throughout this Owners Manual Safety Rules and Important Notes. Make sure you understand and obey these warnings for your own protection.

I. SPECIAL SAFETY INFORMATION

⚠ WARNING

Attention: This symbol points out our important safety instructions. When you see this symbol, **⚠** heed it's warning!! Stay alert!!

⚠ WARNING

To reduce the potential for accidents, comply with the safety instructions in this manual. Failure to comply may result in serious personal injury, and/or equipment and property damage.

II. SAFETY & WARNINGS

⚠ WARNING

Improper use or care of this tiller or failure to wear proper protection can result in serious injury. Read and understand the rules for safe operation and all instructions in this manual. Wear hearing and eye protection.

⚠ WARNING

The engine exhaust from this product contains chemicals known to the State of California to cause cancer, birth defects or other reproductive harm.

III. SAFETY DECAL INFORMATION

An important part of the safety system incorporated in this tiller are the warning and information decals found on various parts of the tiller. These decals must be replaced in time due to abrasion, etc. It is your responsibility to replace these decals when they become hard to read.



P/N 430057



P/N 400631

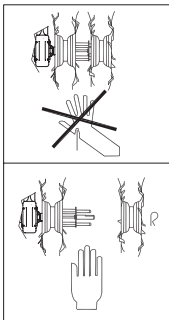

P/N 400635

Do not reach your fingers and/or hands in between the tine blades

Always remove the outer tines before removing the inner tines



Cutting hazard; keep feet and hands away from rotating tines.



Do not carry the tiller in this position.



Read owner's manual before using tiller, or performing any repair or maintenance. Keep owners manual in a safe place.



Don't operate indoors



Don't fuel, refuel, or check fuel while smoking, or near an open flame or other ignition source.



Wear ear and eye Protection.



Caution: when assembling the handles, make sure fuel tank faces away from operator. This is the rear of the tiller, refer to assembly instruction on page 10-11.



Incorrect assembly.

Safety Rules & Warnings

WARNING

If the tiller is used improperly or safety precautions are not followed, the users risk serious injury to themselves and others.
Read and understand this manual before attempting to operate this tiller.

WARNING

Operation of this equipment may create sparks that can start fires around dry vegetation. A spark arrestor is installed. The operator should contact local fire agencies for laws or regulations relating to fire prevention requirements.

IV. WARNINGS - DOS

Read and understand the owner's manual. Pay particular attention to all sections regarding safety.

1. **Always** keep a firm grip on both handles while the tines are moving and/or the engine is running. BE AWARE!! The tines may coast after throttle trigger is released. Make sure tines have come to a complete stop and engine is off before letting go of the tiller.
2. **Always** maintain a firm footing and good balance. Do not overreach while operating the tiller. Before you start to use the tiller check the work area for obstacles that might cause you to lose your footing, balance or control of the machine.
3. **Thoroughly** inspect the area where equipment is to be used and remove all objects, which can be thrown by the machine.
4. **Always** keep area clear of children, pets, and bystanders.
5. **Always** stay alert. Watch what you are doing and use common sense. Do not operate unit when fatigued.
6. **Always** dress properly. Do not wear loose clothing or jewelry, they might get caught in moving parts. Use sturdy

gloves. Gloves reduce the transmission of vibration to your hands. Prolonged exposure to vibration can cause numbness and other ailments.

7. **While working**, always wear substantial footwear and long trousers. Do not operate the equipment when barefoot or wearing open sandals.
8. **Always** wear ear and eye protection. Eye protection must meet applicable CE requirements. To avoid hearing damage, we recommend hearing protection be worn whenever using the equipment.
9. **To reduce fire hazard**, keep the engine, and petrol/gas storage area free of vegetative material and excessive grease.
10. **Start** the engine carefully, according to the manufacturer's instructions and with feet well away from tool(s).
11. **Keep** all nuts, bolts and screws tight to be sure the equipment is in safe working condition.
12. **Use extreme caution** when reversing or pulling the machine towards you.
13. **Work only** in daylight or good artificial light.
14. **Always** be sure of your footing on slopes.

15. **Exercise** extreme caution when changing direction on slopes.
16. **Always** keep a safe distance between two or more people when working together.
17. **Always** inspect your unit before each use. Keep all knobs, nuts, bolts and screws tight to be sure the equipment is in safe working condition.
18. **Before** using your tiller, always visually inspect to see that the tools are not worn or damaged. Replace worn or damaged elements and bolts in sets to preserve balance.
19. **Always** maintain and examine your Tiller with care. Follow maintenance instructions given in manual.
20. **Always** store tiller in a sheltered area (a dry place), not accessible to children. The tiller as well as fuel should not be stored in a house.
21. **Always** keep in mind that the operator or user is responsible for accidents or hazards occurring to other people or their property.
22. **Always** remove the outer set of tines before removing the inner set of tines.

V. WARNINGS - DON'TS

Don't use tiller with one hand. Keep both hands on handles with fingers and thumbs encircling the handles, while tines are moving, and engine is running.

Don't overreach. Keep a good footing at all times.

Don't run with the machine, walk.

Don't work on excessively steep slopes.

Don't attempt to clear tines while they are moving. Never try to remove jammed material before switching the engine off and making sure the tines have stopped completely.

Don't let others operate tiller without proper training.

Do not stand in front of tiller when tines are rotating.

Don't allow children, incapable people or people unfamiliar with these instructions to use the machine. Local regulations can restrict the age of operator.

Don't operate while under the influence of alcohol or drugs.

Safety Rules & Warnings

V. WARNINGS - DON'TS (CONTINUED)

Don't attempt to repair this tiller. Have repairs made by a qualified dealer or repairman. See that only original Mantis parts are used.

Don't operate tiller with tines having the 3 rods extending from end without having second set of tines attached. Failure to have tines in place will damage tine assembly.

Do not reach you fingers and/or hands in between the tine blades.

Do not attempt to remove the inner tines before removing the outer tines.

WARNING

Handle fuel with care, it is highly flammable. Fueling a hot engine or near an ignition source can cause a fire and result in serious personal injury and/or property damage.

VI. ENGINE/FUEL WARNINGS - DOS

Always use fresh gasoline. Stale gasoline can cause damage.

Always store fuel in containers specifically designed for this purpose.

Always add fuel before starting the engine.

Always replace all fuel tank and container caps securely.

Always pull starter cord slowly until resistance is felt to avoid kickback and prevent arm or hand injury.

Always operate engine with spark arrestor installed and operating properly. The use of spark arrestor mufflers is required by law in the state of California (Section 4442 of the California Public Resources Code), as well as in other states or municipalities. Federal laws apply on federal lands.

Stop the engine whenever you leave the machine and before refueling. Allow the engine to cool before storing in any enclosure. Replace worn or damaged parts for safety.

If the fuel tank needs to be drained, this should be done outdoors.

VII. ENGINE/FUEL WARNINGS - DON'TS

Never pick up or carry a machine while the engine is running.

Don't fuel, refuel or check fuel while smoking, or near an open flame or other ignition source. Stop engine and be sure it is cool before refueling.

Don't leave the engine running while the tiller is unattended. Stop the engine when carrying out maintenance and cleaning operations, when changing tools and when being transported by means other than under its own power.

Never remove the cap of the fuel tank or add petrol while the engine is running or when the engine is hot.

Don't refuel, start or run this tiller indoors or in an improperly ventilated area.

Don't run engine when electrical system

causes spark outside the cylinder. During periodical checks of the spark plug, keep plug a safe distance from cylinder to avoid burning of evaporated fuel from cylinder.

Don't check for spark with spark plug or plug wire removed. Use an approved tester.

Don't crank engine with spark plug removed unless spark plug wire is disconnected. Sparks can ignite fumes.

Don't run engine when the odor of gasoline is present or other explosive conditions exist.

Do not attempt to start the engine if petrol is spilled, but move the machine away from the area of spillage and avoid creating any source of ignition until petrol vapors have dissipated.

Don't operate your tiller if there is an accumulation of debris around the muffler, and cooling fins. To reduce the fire hazard, keep the engine and petrol storage area free of vegetative material and excessive grease.

Don't touch hot mufflers, cylinders or cooling fins as contact may cause serious burns.

Don't change the engine governor setting or over speed the engine.

Don't attempt to remove spark plug while engine is hot. Removing a spark plug from a hot engine can cause irreparable damage to the engine and will void your warranty.

Don't use starter fluids as they will cause permanent engine damage.

Assembly

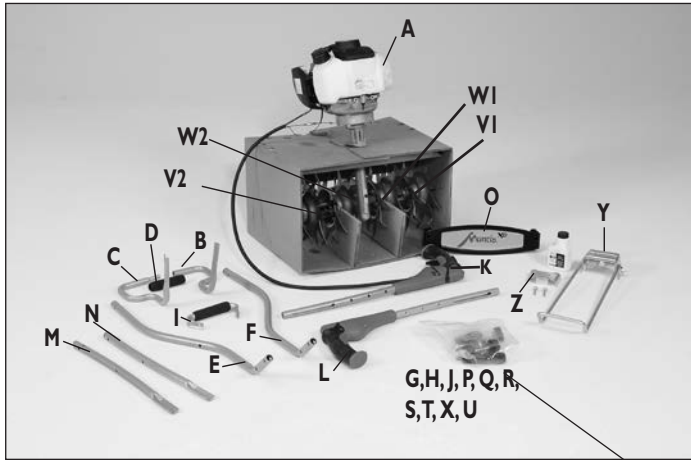

WHAT COMES IN THE BOX

Key	Qty.	Part No.	Description
A	1	N/A	Transmission and Engine Assembly
B	1	430023	Loop Handle, Right Half
C	1	430022	Loop Handle, Left Half
D	1	430025	Foam Grip
E	1	430051	Lower Handle with Plug, Right
F	1	430050	Lower Handle with Plug, Left
G	2	4049	Bolt 1/4-20 X 3.25"
H	6	972	1/4-20 Two-Way Lock Nut
I	1	430049	Carry Handle with Grip
J	4	144-2	1/4-20 X 1.125" Hex Head Cap Screws
K	1	430004	Trigger Handle Assembly, 4-Cycle Engine, Right
L	1	430006	Handle Assembly, Left
M	1	430053	Middle Handle with Plug, Right
N	1	430052	Middle Handle with Plug, Left
O	1	430021	Handle Brace
P	2	430038	Knob, 1/4-20 X 1.5 Male
Q	4	400523	Knob, Two Prongs, Female
R	2	430039	Carriage Bolt, 1/4-20 X 2.25"
S	2	430048	Curved Head Bolt, 1/4-20 X 2"
T	2	395	Acorn Nut
U	2	478	Throttle Clip
V-1	1	400328	Tine Assembly, Outer Right
V-2	1	400327	Tine Assembly, Outer Left
W-1	1	400330	Tine Assembly, Inner Right
W-2	1	400329	Tine Assembly, Inner Left
X	2	418-1	Tine Retaining Pins
Y	1	410158	Kickstand, Stand Assembly
Z	1	430037	Kickstand, Bracket and Hardware

WARNING

Improper assembly of this tiller can result in serious injury. Make sure to follow all instructions carefully. If you have any questions, contact our factory at 1-800-366-6268 or an authorized Mantis dealer.

Bag Contents

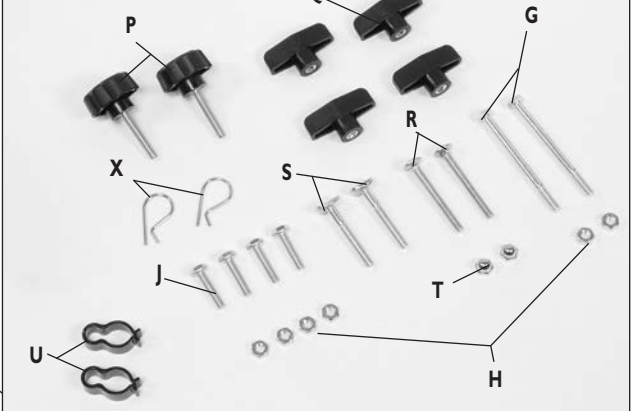

Congratulations! You have just purchased a super high-quality product, the Mantis® Deluxe XP Tiller/Cultivator.

This manual will show you how to Assemble, Start, Operate, Transport, Store and Maintain your tiller. The Mantis® Deluxe XP Tiller/Cultivator is designed to bring you years of solid, reliable performance.



WHAT YOU WILL NEED TO ASSEMBLE THE TILLER

Prior to removing the contents and assembling, it is important to:

- Have a clean work area
- Make sure all necessary tools are handy
- You will need a 7/16" crescent wrench
- A ratchet wrench with an extension
- A 7/16" socket
- A 3/8" socket or crescent wrench

Assembly

LET'S BEGIN

- With the box upright, open the box and remove insert.
- Remove second cardboard insert and all loose parts that are at the top of the tillers cradle.
- Lay the box on the side and open the bottom flaps.
- Return the box to an upright position and pull the box straight up.
- Right throttle handle attached to tiller assembly with installed tines will be in the box cradle.
- Lay everything out so you can easily identify the parts (see parts image and list on page 7).



LOWER HANDLE ASSEMBLY



- For ease of assembly and stability it is important that you keep the engine assembly in its cardboard cradle.

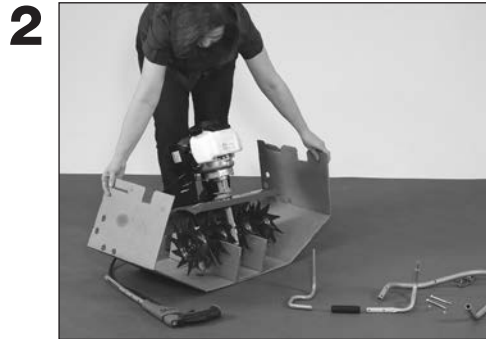

- Open cradle by pulling sides apart.



- Slide the foam grip onto the right loop handle.



- Line up the holes of the right loop handle with the holes of the lower right handle.
- Slide the two 3.25" bolts through the hole.



- Position this assembly onto the recessed channels below the engine.



- Slide the lower left handle onto the bolts.

Assembly

LOWER HANDLE ASSEMBLY (CONTINUED)



- Slide the left loop handle into the foam grip and right loop handle.



- Slide loop handle through bolts and over top lower left handle, then take two lock nuts and fasten them finger tight.



- Place the carry handle between the lower handles and line up the holes
- Place two of the 1.125" bolts through holes with hex head on inside of carry handle and with two lock nuts fasten them tight with wrench and socket.



- Use the 7/16" wrenches and socket to tighten the rest of the handle bolts.

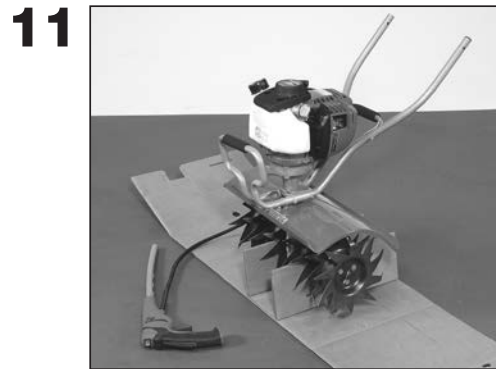

- At this point, your Mantis[®] Deluxe XP Tiller should look like this when lower handle assembly is complete.

KICKSTAND ASSEMBLY

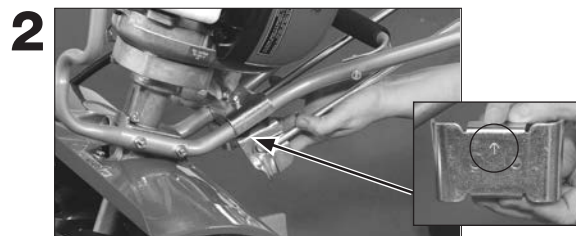

- Position the kickstand bracket just above the bend of the lower handles. The stamped arrow should be pointing up.
- Position the kickstand under the lower handles, line up the holes and thread the kickstand bracket bolts into the kickstand.
- Tighten with the 3/8" crescent wrench.

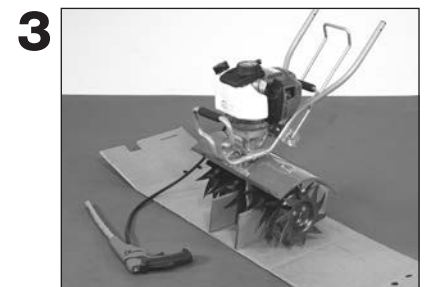

- Your Mantis[®] Deluxe XP Tiller will look like this when lower handle assembly and kickstand is complete.

Assembly

UPPER HANDLE ASSEMBLY

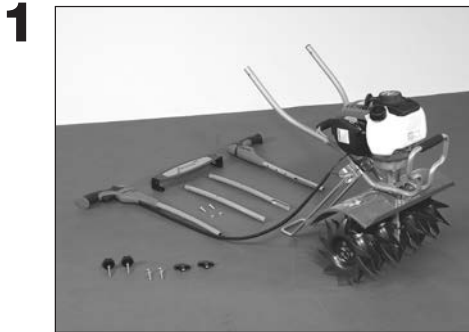

- To assemble the upper handles, first put the kickstand down.

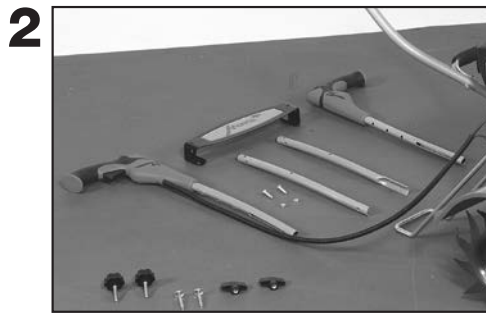

- Layout the middle and upper handles and the handle brace as shown above.



- Take the right middle handle and attach the brace using a hex head cap screw and a 2-way lock nut. Finger tighten.
- Repeat for left side.



- Take the right upper handle, the one with the throttle, and slide it between the middle handle and the lower flange of the brace.



- Insert a curved head bolt into the slot at the bottom of the upper handle so that it comes out the top of the middle handle.



- Thread a 2-pronged knob onto the bolt two full turns while leaving it loose.
- Repeat for left side.



- Line up the top holes of the upper handles with the holes on the top of the brace so the handles are in the lowest position.



- Insert the round knob into the brace and tighten.



- Now fully tighten the lower 2-prong knobs.

IMPORTANT NOTE:

Make sure you have installed the handles properly. When you stand behind your tiller, holding the handles, the fender warning label should face you.

IMPORTANT NOTE:

Be sure you have proper throttle movements and that the throttle cable is not wrapped or twisted around the handle bar. Hold down the lockout lever, fully squeeze the throttle trigger and let go. Engine throttle triangle must click in both directions. If there is any doubt, remove air filter and visually check that the throttle triangle hits both the idle screw and the full open stop. **THIS MUST BE DONE BEFORE STARTING THE ENGINE.**

Assembly

UPPER HANDLE ASSEMBLY (CONTINUED)



- With a 7/16 in. wrench and socket, tighten the nuts and bolts that hold the brace onto the handles.



- Insert the carriage bolts into the bottom holes of the upper handles then through the top holes of the lower handles.



- Loosely thread the other 2-pronged knobs onto the carriage bolts.



- Lift the upper handles until they line up with the lower handles and fully tighten the knobs at the pivot point.



- Cap the exposed bolts with the acorn nuts and tighten with your 7/16" wrench until snug. Do not over tighten.



- Attach the throttle cable clips to the upper and lower handles. Make sure the cable is not wrapped or twisted and you have the proper throttle movement.
- * See important notes listed below.

UPPER HANDLE POSITIONING



- Adjust your handle height by loosening the upper 2-prong knobs and removing the round knobs then sliding the upper handles to the desired position.

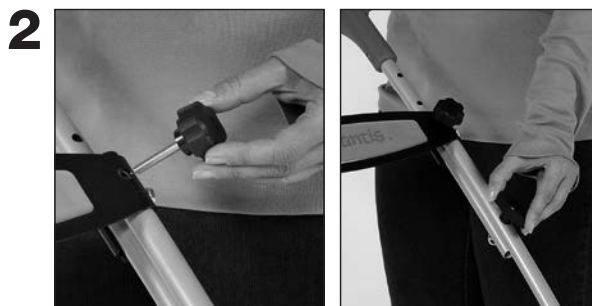

- Then re-insert the round knobs and re-tighten the 2-prong knobs.



WARNING

Improper Throttle installation can cause tines to rotate unexpectedly.

IMPORTANT NOTE:

Before you use your Mantis[®] Deluxe XP Tiller, read the Safety Rules & Warnings on pages 4-6

Mantis® Deluxe XP Tiller Fueling & Starting

MANTIS® DELUXE XP TILLER FUELING AND OIL

IMPORTANT!

It is normal for your 4-stroke engine to smoke for the first minute or two of operation, however it is not necessary for this to occur every time. This is a result of the oil being pulled through the engine for lubrication.

- Rock the tiller forward so that it rests on its front loop handle.
- It is important to position the Mantis® Deluxe XP Tiller as shown in **Figure 1** so the oil will properly fill the crankcase. Failure to do so will cause engine damage.
- Remove the oil plug.
- Pour in the bottle of pre-measured, Mantis approved, 4-cycle engine oil.
- Always check the oil level before each use. The oil level should reach the inner first thread of the reservoir. Do not overfill.
- Replace the oil plug.
- Then return the unit to the upright position and put the kickstand down.



Figure 1

Fueling your Mantis® Deluxe XP Tiller/Cultivator is easy. Unscrew the gas cap and fill the tank about four-fifths of the way up with 89 octane unleaded gasoline. And remember, always drain the gas when transporting the unit from one location to another.

MANTIS® DELUXE XP TILLER STARTING ONLY

Starting the engine for the first time, or “cold starting”, is easy.

- First, make sure the start/stop switch, located on the throttle handle, is in the start position, which is indicated by the “I” symbol.
- Close the choke by moving the choke lever to the up position.
- Press the primer bulb approximately 6 times until the bulb is filled with gas. Once it is filled, press it two more times.
- Pull the starter cord lightly until you feel resistance and then give it a short, brisk pull. Your tiller should start immediately. Do not pull the cord all the way out and do not let it snap back into the starter housing.
- Once it is running, open the choke. Ensure the lever is fully down.
- To stop the engine, simply push the start/stop switch to the stop position “O.”
- To start a warm engine, follow the same procedure. Except now you can leave the choke lever in the down position and there is no need to pump the primer bulb.
- Before using the tiller, let the engine run for a minute to warm up. And before shutting it down, let the engine run briefly to cool down.



Switch on

IMPORTANT NOTE:

Check the oil level in the engine before each use. If oil is low see your 4-Stroke Tiller Engine Manual and information above for details.

Never use starting fluids as they will cause permanent engine damage. Using them will void the warranty. Before you use the tiller, read the Safety & Warning rules on pages 4-6.

WARNING

Do not operate the engine in a confined space where dangerous carbon monoxide fumes can collect.

WARNING

Fuel is extremely flammable. Handle it with care. Keep away from ignition sources. Do not smoke while fueling your equipment

WARNING

Avoid accidental blade engagement. Do not squeeze the throttle trigger when starting. Maintain proper idle speed adjustment (2500-3100 rpm)

Mantis® Deluxe XP Tiller Fueling & Starting

CORRECTIVE ACTION

If you suspect the engine is overfilled the following procedure should remove the excess oil from the crankcase and valve cover.

If the engine is overfilled, oil will enter the crankcase and it does not simply pour out of the oil fill opening. The excessive oil has to be pumped out as the engine runs. Checking the oil level and draining any excess between multiple 30 second running intervals will bring the oil back to the proper level.

1. Place the engine on a level surface resting flat on the front

loop handle and remove the oil fill cap/dipstick. Use a catch basin for any oil that overflows from the oil fill opening.

2. Replace the oil fill cap/ dipstick and run the engine for approximately 30 seconds then repeat step one. Continue steps 1 & 2 until oil no longer overflows when the oil fill cap/ dipstick is removed.
3. Once the oil level is corrected the engine may continue to smoke while running for several minutes while the residual oil burns off.

MANTIS® DELUXE XP TILLER PROPER OIL FILL/LEVEL CHECK POSITION



This position does not allow for a proper oil level reading and may cause overfilling.

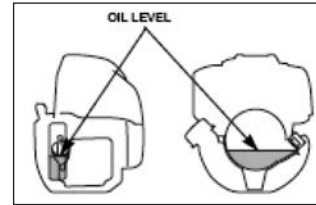

Engine must be resting on a flat surface on the fuel tank

Mantis® Deluxe XP Tiller Operation

⚠ WARNING

If engine does not stop when switch is put in the stop position, release the throttle, allow engine to idle. Put the tiller down, and slide the choke lever to the cold start (closed) position. Have product serviced.

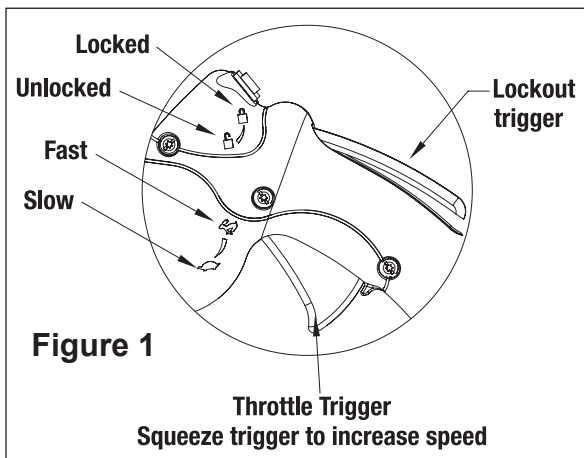

A SPECIAL FEATURE

(With the idle set properly and the engine running)

Even when the engine is running, the tines won't turn unless you squeeze the throttle trigger on the handlebars. And, when you release the throttle trigger, the tines will stop.

A TIP FOR EXTENDING YOUR ENGINE'S LIFE

After you start the engine, let your tiller warm up for two to three minutes before you use it. Then,

before you put your tiller away, let it idle for a minute to give the engine a chance to cool down.

OPERATION

With engine running, and both hands on the handles, hold down the throttle lock out lever (**Figure 1**), then squeeze the throttle trigger gradually to increase the engine speed and engage the tines.

NOTE: This step must be repeated each time your tiller trigger is released.

Mantis® Deluxe XP Tiller Operation

WARNING

Read the instructions carefully. Be familiar with the controls and the proper use of the equipment.

NOW YOU'RE READY TO USE YOUR MANTIS® DELUXE XP TILLER.

If you've seen other tillers, your Mantis® Deluxe XP Tiller may surprise you. It tills best when you pull it backward! You see, when you pull your Mantis® Deluxe XP Tiller backward, you give extra resistance to the tines, so they dig deeper.

(Figure 1)

In addition, when you go backward, you erase your footprints. So your soil stays light and fluffy. With other tillers, by contrast, you walk right over the soil you've just tilled, packing it down, so it's less plantable.

RUN YOUR MANTIS® DELUXE XP TILLER LIKE A VACUUM CLEANER

Place your Tiller at the head of the row or area you want to till. Start it up. Then

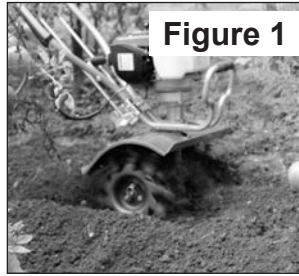

Figure 1



Figure 2



Figure 3

use an easy rocking motion. First, pull your Tiller backward. Then use an easy rocking motion. Again, pull your Tiller backward. Then, let it move forward just a little bit. Then pull it backward again. This will help you till deeper.

Keep repeating these steps until you've tilled an entire row. Start again on the next row. It's much like running a vacuum cleaner! (Figure 2)

YOU CAN EVEN CONTROL DEPTH.

For Deeper Tilling:

Move your Tiller slowly back and forth, as you would a vacuum cleaner. Work the same area over and over until you've dug to your desired depth. (Figure 3)

For Shallow Tilling:

Switch the tines to the cultivating

position. (See page 15 to learn how.) Then move your Tiller quickly over your soil surface.

For Big Weeds or Tough Roots:

Let your Tiller rock back and forth over the tough spot, until the tines slice through the weed or root.

Your MANTIS® Deluxe XP Tiller Handles Special Tilling Projects:

Want to turn part of your lawn into a colorful flower border? Your Mantis® Deluxe XP Tiller makes it easy! Just run your Tiller back and forth until the sod begins to break up. Then continue tilling. Your Tiller will chop the clumps of sod until they're fine. Then, it will work them into the soil. Pretty soon, you'll have a soft, fresh planting bed.

WARNING

If your tines get jammed or entangled, shut off the engine at once. Remove the obstruction while the engine is off. Never try to remove an obstruction while the engine is running. Serious injury can result.

WARNING

The operator of this tiller is responsible for accidents or hazards occurring to himself, other people or their property.

YOUR MANTIS® DELUXE XP TILLER MAKES WEEDING A PLEASURE!

As a tiller, your Mantis® Deluxe XP Tiller works the soil down to 10" (25 cm) deep. But, as a cultivator, it gently cultivates the surface, only 2" to 3" (5 cm to 8 cm) deep.

First, you must switch the tines to the

weeding, cultivating position. This takes less than a minute.

Then, your Mantis® Deluxe XP Tiller's sharp "tine teeth" will slice up those pesky weeds, burying them as you go along. And, since the tines in this

position won't dig too deep, they won't hurt your plants' precious root systems.

The result? Your Tiller will cut your weeding time in half, and turn a tiresome chore into a pleasure.

Mantis® Deluxe XP Tiller Operation

HOW TO SWITCH FROM TILLING TO CULTIVATING POSITION

1. First, you will need to understand that your Mantis® Deluxe XP Tiller has an inner and an outer set of tines on each side of the tiller as shown in **Figure 1**.
2. Make sure the tiller is turned off.
3. Remove the retaining pins from the outer set of tines (**Figure 2**) and remove the outer tines.
4. Only after you have removed the outer set of tines, then remove the retaining pins from the inner tines and remove the inner tines from the transmission axle (**Figure 3**).
5. Place the right-side set of inner tines onto the left-side. The “D” shaped hole should be to the outside. Make sure the tine retaining pin is installed. Repeat for the other side.
6. Place the right side set of outer tines onto the left-side axle. The “D” shaped hole should be to the outside and insert the tine retaining pin. Repeat for the other side.

simply remove the inner and outer tines as noted above. Then just put the outer tines back onto the transmission axle and secure with a retaining pin on each side.

WARNING

DO NOT reach your fingers and/or hand between the tine blades.
DO NOT attempt to remove the inner set of tines until you have first removed the outer set of tines.

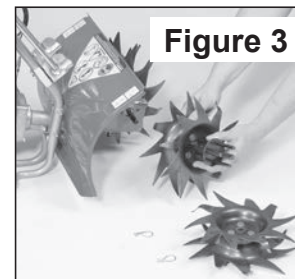
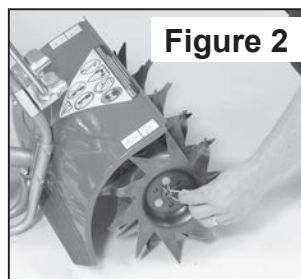
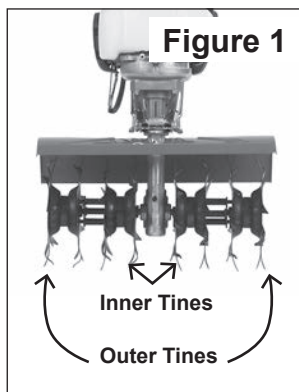

Tilling

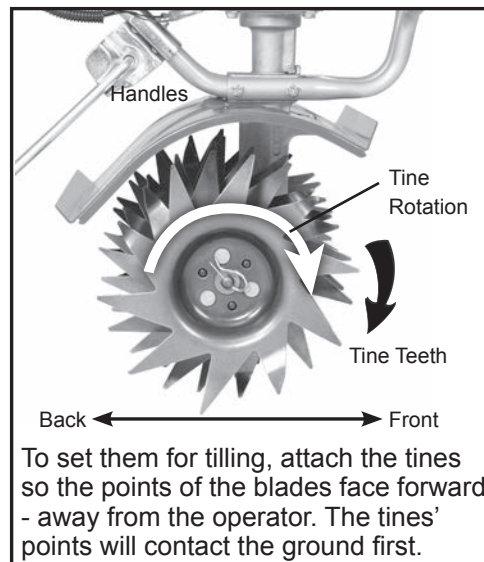

Cultivating

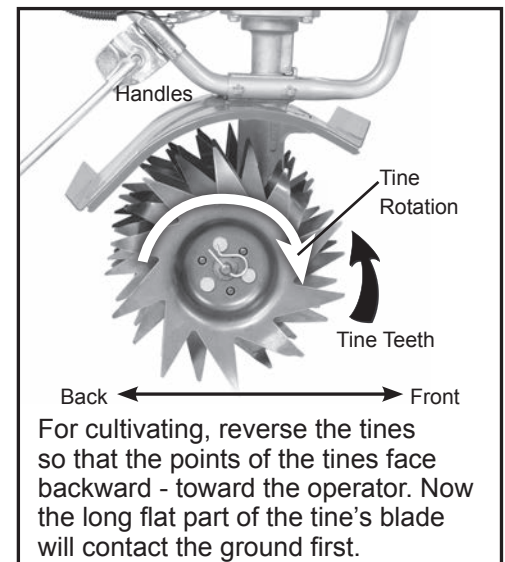

IMPORTANT:

To change the tines on your Mantis® Deluxe XP Tiller, push the tiller forward and allow it to rest on the loop handle.



Mantis[®] Deluxe XP Tiller Operation

YOUR MANTIS[®] DELUXE XP TILLER CAN WEED BETWEEN ROWS!

Your Mantis[®] Deluxe XP Tiller is a precision weeder that can easily fit in tight places. So don't be afraid to weed anywhere: between plants and shrubs, in corners, against fences, on raised beds, in wide rows, even in very narrow rows.

Your Mantis[®] Deluxe XP Tiller weeds six* to nine inches wide. So you can run it in a tightly planted garden without damaging your delicate plants. That's good news for suburban gardeners, who often have to plant rows close together!

To do this you must take off the tine assemblies (both sides) and replace with only the outer set of tines. Do not operate with only the inner set of tines. Damage will occur using this set of tines.

*With optional Planter Furrower attachment. (Item #6222)

CLEANING THE TINES

If you have a "backyard jungle," first use a knife, pruner, or brush cutter to chop up the overgrowth. If the tines become tangled anyway, turn the engine off completely before trying to clear them.

From time to time, you may want to remove the tines to get them completely

clean. To do this, please follow steps 1-4 as noted under "How to Switch From Tilling to Cultivating Position" on page 15. Then, you can remove any weeds, stones, or mud from the tines. As always, please be sure to remove the outer tines before removing the inner tines. Also, do not reach your fingers and/or hand in

between the tine blades. When finished, simply return the tines to their starting positions.

The optional Tine Detangler (Item #1322) will clear tines in a jiffy. Contact your local authorized Mantis[®] dealer or call 1-800-366-6268 to order.

Mantis[®] Deluxe XP Tiller Transportation



Figure 1



Figure 2

MANTIS[®] DELUXE XP TILLER TRANSPORTATION

Transporting your tiller is easy. It's light enough and easy to carry using the carrying handle as seen in **Figure 1**.

Or, with it running, you can walk it by gently squeezing the throttle until it moves at a comfortable

pace seen in **Figure 2**.

Your tiller is easily transported in the back of a car or truck. Be sure to empty the fuel tank (This is crucial)! Then stow your tiller in the trunk of your car or truck.

WARNING

Never store the equipment with Fuel in the tank or inside a building where fumes can accumulate and breach an open flame or spark

Tiller Storage

MANTIS® DELUXE XP TILLER STORAGE

WARNING

Do not store in an area where fuel fumes may accumulate and reach a flame or spark.

Each fall, or before you store your Mantis® Deluxe XP Tiller for any long period, be sure to take these measures:

1. Do not store your tiller with fuel still in it. Even under ideal conditions, stored fuel containing ethanol or MTBE can start to go stale in 30 days. And, since stale fuel has a high gum content, it can clog the carburetor, this, in turn, will restrict fuel flow. Therefore, when you're ready to store your tiller, or will not be using it for more than 2 weeks, drain the fuel tank completely.
2. Next, restart the engine to make sure no fuel is left in the carburetor.

Then, run the engine until it stops. This will prevent gum deposits, forming inside of the carburetor and possible engine damage.

3. Disconnect spark plug wire and remove the spark plug. Slowly pull the starter cord once.
4. Inspect the spark plug, and if necessary, clean it. If you need to replace it, buy a NGK-CMR5H.
5. Install the spark plug, but leave the spark plug wire disconnected.
6. Clean the air filter as directed in your 4-Stroke Engine Manual.
7. Wipe the tines with oil or spray them with WD-40, to prevent rusting.
8. Oil the throttle cable and all visible moving parts. (Do not remove the engine cover.)
9. Check the grease level in the worm gear housing as described on page 19.

10. Store your tiller in an upright position in a clean, dry place. You can store with the handles in an extended position (**Figure 1**) or folded down (**Figure 2**).

To fold the handles down, simply loosen the lower 2-pronged knobs until you can pivot the upper handles down.

11. To fold the handles, follow these easy steps: Loosen the handle knobs (#40) then fold the handles forward. Tighten knob securely. Your handles are now folded and ready to store in a smaller area.
12. Do you have fuel left over from last season? Dispose of it properly. Buy fresh oil and gasoline next season.
13. Remove tilling tines or attachments and lightly oil tine shaft at least once a year.



Figure 1

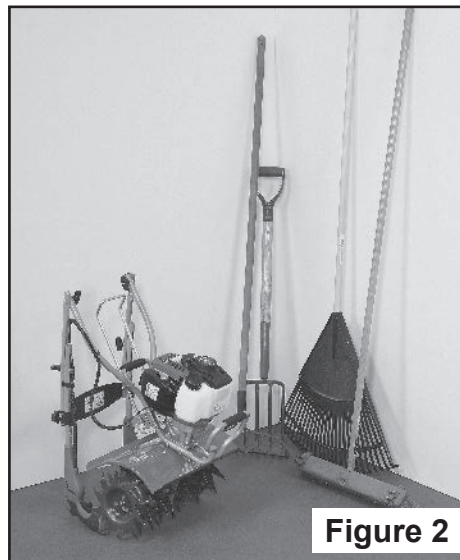

Figure 2

IMPORTANT:

It is important to store your Mantis® Deluxe XP Tiller in an upright position. Laying the Tiller on its side will cause the oil to leak out of the engine through the air cleaner case.

IMPORTANT:

Avoid any orientation that places the top cover (engine head) down -this may allow oil from the crankcase to enter the combustion chamber and cause hard starting or a locked piston.

Tiller Maintenance

MANTIS[®] DELUXE XP TILLER BASIC MAINTENANCE

Your Mantis[®] Deluxe XP Tiller will require some basic maintenance to keep it performing year after year.

If you are storing your tiller for the season or longer than 30 days it is very important to empty the fuel tank to prevent engine damage.

Undoubtedly, you will be putting your tiller through rigorous use.

Check engine oil level, air filter and fuel filter.

Refer to your Honda[®] engine manual for more details.



Air Filter

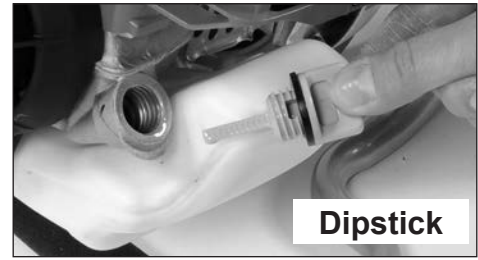

Dipstick



Fuel Filter

HOW TO RESEAT THE FLANGE

At some point, you may find that the tines won't turn when you squeeze the throttle. This may mean the engine isn't sitting all the way down on the worm gear housing.

Perhaps you've been using your tiller for several years. The flange bolt (Key #12, Page 22) may have come loose and lifted the engine up.

If this happened, you'll notice a gap between the bottom of the engine flange (Key #43, Page 22) and the top of the worm gear housing. **(Figure 1)**

To fix this, loosen the flange bolt. Take the engine off the worm gear housing. Notice the hex head on top of the drive shaft (Key #22, Page 22). Inside the flange housing, you'll find the clutch drum (Key #57, Page 22). Make sure the hex head lines up with the clutch drum inside the flange housing.

Then put the engine back on the worm gear housing. Make sure the plastic carrying handle is not under the engine.

If you've followed these steps properly, there will be no gap between the engine flange and the worm gear housing.

(Figure 2) Make sure you tighten the flange bolt!

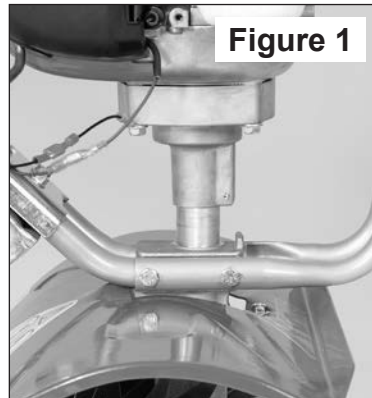

Figure 1

Note how the engine doesn't sit all the way down on the transmission.

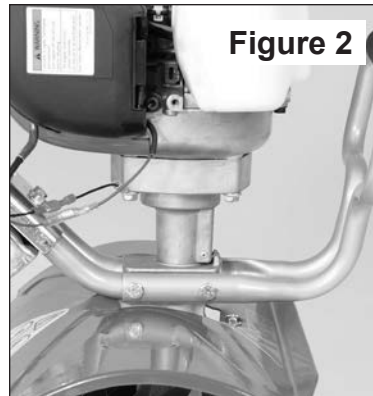

Figure 2

Note how the engine sits all the way down on the transmission.

AIR FILTER MAINTENANCE

A wet or dirty air filter can affect the way your engine starts, performs, and wears. So, it's a good idea to check your air filter once a month.

If you work in dusty soil, or if you want to be on the safe side — then check your filter more often (for instance, before each use). But be sure to replace it at least once a year, in the spring or fall.

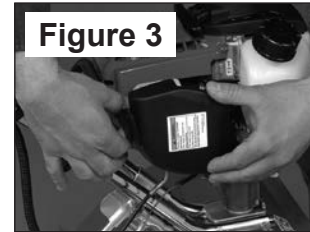

Figure 3

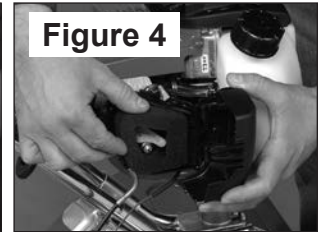

Figure 4

How to Check, Clean and Change the Air Filter

1. The air filter is held in the air cleaner in a black housing on the side of the tiller, behind the gas tank cap.
2. Squeeze the two locking tabs at the rear of the air cleaner cover **(Figure 3)** and swing the cover towards the front of the engine to open it
3. The air filter is the dark sponge like material on the inside of the air cleaner. Check whether it is soiled or moist.
4. If the air filter needs to be cleaned or no longer fits properly, simply remove it by carefully peeling it out of the air cleaner. **(Figure 4)**

Deluxe XP Tiller Basic Maintenance

AIR FILTER MAINTENANCE

5. To clean the air filter
 - a. Clean the filter element in warm soapy water, rinse and allow to dry thoroughly. Or, clean in a non-flammable solvent and allow to dry.
 - b. Dip the filter element in clean engine oil, then squeeze out all excess oil. The engine will smoke when started if too much oil is left in the element.
 - c. Wipe dirt from the air cleaner body and cover, using a moist rag. Be careful to prevent dirt from entering the carburetor.
6. Insert your clean filter inside the air cleaner.

IMPORTANT:

Make sure the filter is “seated” properly in the cover. The filter must fit snugly inside the opening that holds the filter in place. Installing the filter incorrectly will cause engine damage and void the warranty. Fit the cover back over the air cleaner and snap the two locking tabs

IMPORTANT NOTE:

A dirty air cleaner will restrict air flow to the carburetor, reducing engine performance. If you operate the engine in very dusty areas, clean the air filter element more often than specified in the Maintenance section.

IMPORTANT NOTE:

Operating the engine without an air filter element, or with a damaged air filter element, will allow dirt to enter the engine, causing rapid engine wear. This type of damage is not covered by the Limited Warranty

IMPORTANT NOTE:

Please check the lip on the Air Cleaner Cover. If the lip is chipped or cracked, it should be replaced. This will prevent dirt from being ingested through the carburetor into the inside of the engine.

Deluxe XP Tiller Basic Maintenance

TRANSMISSION CARE

How to Check the Grease Level Inside the Worm Gear Housing

When we built your Mantis® Deluxe XP Tiller, we added Lithium EP #0 grease to properly lubricate the transmission for the first 10 hours of operation. As part of the regular maintenance of your tiller, it is imperative that you inspect the grease level and add grease if necessary. This will help your tiller give you years of excellent usage.

You will need to add grease with a grease gun using the fitting at the front of the transmission (**Figure 1**). You should add grease through this fitting after the first 10 hours of operation and then every 50 hours of use.

WARNING

Premature transmission failure can occur if proper grease level is not maintained

You can use Lithium EP#0 EP#1 grease or #2 grease in combination with specially formulated Mantis® grease (p/n 9985).

The following are different service steps for different type of grease.

IF YOU USE Lithium EP #1 or #0 grease:

1. Make sure the tiller is turned off and remove the tines.
2. Place the tiller front side down on an elevated surface and remove the 4 screws holding the transmission cover (**Figure 2**).
3. Remove the transmission cover and gasket. Inspect the grease level. If it is below the edge of the gear housing, you will need to add grease. If it is already flush with this edge, you do not need to add grease.
4. If grease is needed, remove the protective cap from the grease fitting,

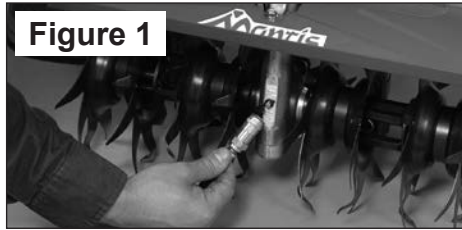

attach the grease gun, and slowly add grease until the level is flush with the edge of the transmission (**Figure 3**).

5. Return the grease fitting protective cover, gasket and attach transmission cover with the 4 original screws.

IF YOU USE Lithium EP #2 grease in combination with Mantis® grease (p/n 9985):

Follow steps 1 through 3 and then follow instructions below.

4. If grease is needed, remove protective cap from the grease fitting on the front of the transmission and attach the grease gun. Please pay attention to the size of the grease gun. Different guns distribute different amount of grease per pump.
 - a. If you are using Mini grease gun with **3 ounce cartridge** add **5 full pumps** of grease. One pump from Mini grease gun is equal to approximately 0.012 oz. or 0.3 grams.
 - b. If you are using standard automotive grease gun with 14 ounce cartridge, add 2 full pumps of grease. One pump from a standard automotive grease gun is equal to 0.03 oz. or 0.9 grams.

CAUTION: DO NOT ADD MORE GREASE THAN SPECIFIED ABOVE

5. Remove the grease gun from the grease fitting and replace the

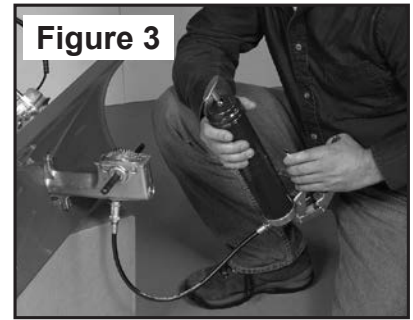

protective cap.

6. Inspect the grease level. If it is below the edge of the gear housing, you will need to add grease. If it is flush with the gear housing do not add grease.
7. If you need to add more grease, utilize the specially formulated Mantis grease (p/n 9985). This grease is compatible with the grease that was in the transmission from the factory. **DO NOT USE Lithium EP #2 IN THIS STEP. (Figure 4)**
8. Return the gasket and the transmission cover. Secure cover with the 4 original screws.

Always inspect the gasket prior to re-installation. If the gasket is damaged, replace it with a new gasket (p/n 436)

WARNING

DO NOT OVERFILL. Too much grease can create pressure which can cause seals to fail or the clutch to slip.

In between adding grease with the grease gun, you should inspect the grease level after approximately 10 hours of operation. If grease is needed, you can add grease directly to the opening in the transmission using Mantis® p/n 9985.

Mantis[®] Deluxe XP Tiller Assembly

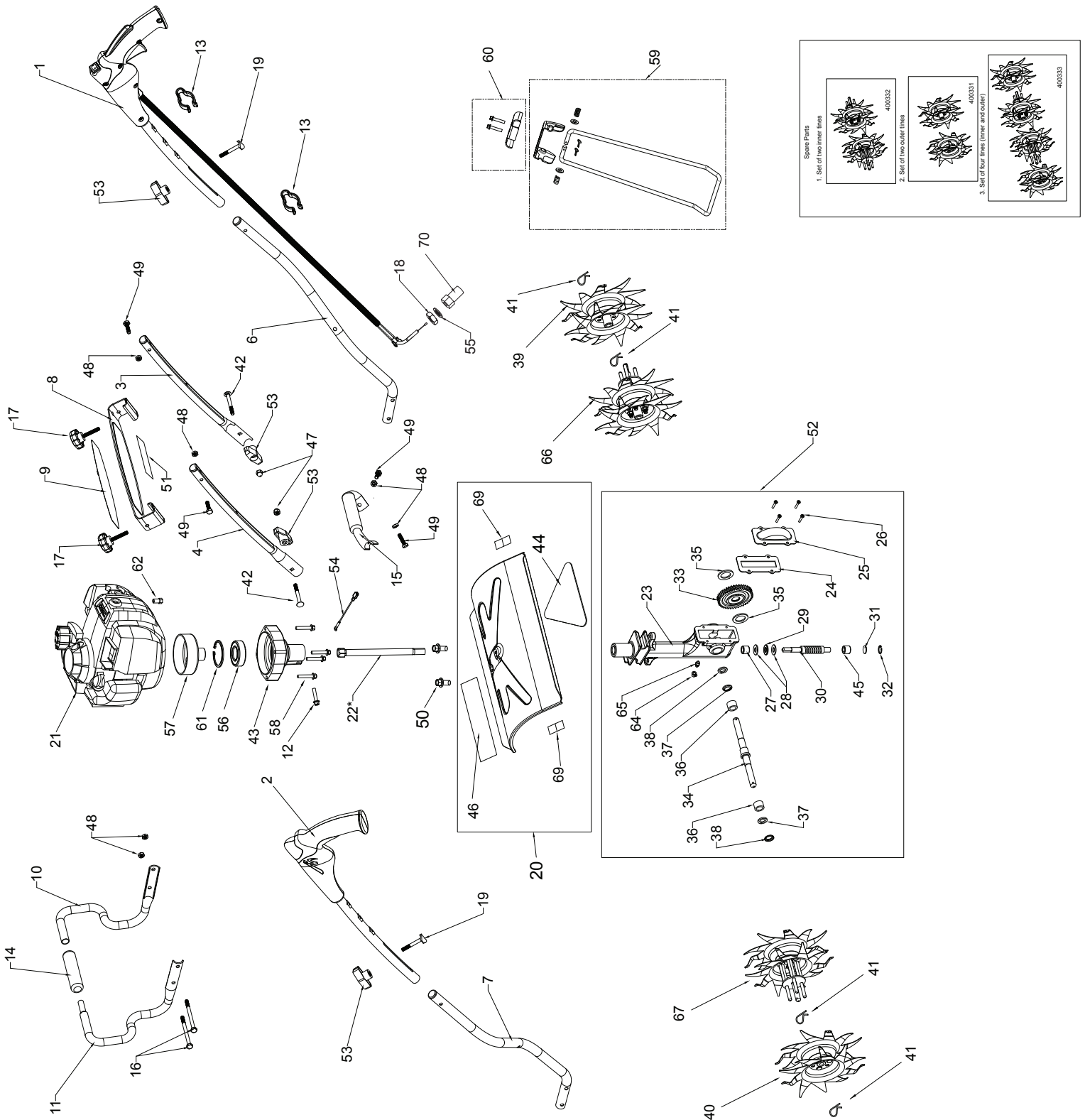

Key	Qty.	Part No.	Description
35	2	430	Worm Gear Thrust Washer
36	2	432	Worm Gear Bearing
37	2	434	Bearing
38	2	435	Bearing Seal Retainer
39	1	400328	Tine Assembly, Outer Right
40	1	400327	Tine Assembly, Outer Left
41	2	418-1	Tine Retaining Pin
42	2	430039	Carriage Bolt 1/4-20 X 2.25"
43	1	400307	Engine Flange
44	1	400631	Triangle Warning Label (4 Cycle Engine)
45	1	458	Roller Bearing
46	1	430058	Mantis Logo Label
47	2	395	Acorn Nut
48	6	972	1/4-20 Two-Way Lock Nut
49	4	144-2	1/4-20 X 1.125 Hex Head Cap Screw
50	2	M9452	Bolt 1/4-20x1/2" Long
51	1	430057	Warning Label
52	1	400302	Transmission Assembly*
53	4	400523	Knob, Two Prongs, Female
54	1	430043	Ground Wire Jumper, 4 Cycle Engine
55	1	4079	M6 Internal Lock Washer
56	1	400132	Bearing
57	1	400308	Clutch Drum
58	4	400529	M6x33mm Flange Bolt
59	1	410158	Kickstand, Stand Assembly
60	1	430037	Kickstand, Bracket And Hardware
61	1	400524	Retaining Ring
62	1	400310	Throttle Stop, Honda® 34cc
64	1	400313	Dust Cap for Grease Fitting
65	1	400300	Grease Fitting
66	1	400330	Tine Assembly, Inner Right
67	1	400329	Tine Assembly, Inner Left
69	2	400635	Label XP Tine Warning
70	1	400310	Throttle Stop

Key	Qty.	Part No.	Description
1	1	430004	Trigger Handle Assembly, 4 Cycle Engine, Right
2	1	430006	Handle Assembly, Left
3	1	430053	Middle Handle W/Plug, Right
4	1	430052	Middle Handle W/Plug, Left
6	1	430051	Lower Handle W/Plug, Right
7	1	430050	Lower Handle W/Plug, Left
8	1	430021	Handle Brace
9	1	400638	Label, Handle Brace
10	1	430023	Loop Handle Right Half
11	1	430022	Loop Handle Left Half
12	1	910502	10-32 X 3/4" Flange Bolt
13	2	478	Throttle Clip
14	2	430025	Foam Grip
15	1	430049	Carry Handle W/Grip
16	2	4049	Bolt 1/4-20 X 3.25"
17	2	430038	Knob, 1/4-20 X 1.5 Male
18	1	4078	M6 Jam Nut
19	2	430048	Curved Head Bolt, 1/4-20 X2"
20	1	400209	Fender Guard with Labels
21	1	400916	Engine Assembly-35cc Honda®
22	1	468	Drive Shaft
23	1	400301	Worm Gear Housing
24	1	436	Gasket
25	1	437A	Gear Housing Cover
26	4	651	#8 Self Tapping Screw
27	1	423	Roller Bearing
28	2	425	Worm Bearing Race
29	1	424	Worm Thrust Bearing
30	1	422	Worm Shaft
31	1	426	Worm Disk
32	1	428	Retaining Ring
33	1	429	Worm Gear
34	1	431	Tine Shaft

* Includes Key #22

Troubleshooting

Problem	Cause	Remedy
1. Tines don't turn when throttle is depressed.	<ul style="list-style-type: none"> • Engine is not seated properly on the gear housing. 	<ul style="list-style-type: none"> • Re-install engine following the instructions on page 18 (How to reseal the flange).
2. Engine fails to start.	<ul style="list-style-type: none"> • O/I switch is in "O" position. • No fuel in tank. • Fuel strainer clogged. • Fuel line clogged. • Spark plug shorted or fouled. • Spark plug is broken (cracked porcelain or electrodes broken). • Ignition lead wire shorted, broken or disconnected from spark plug. • Ignition inoperative. 	<ul style="list-style-type: none"> • Move switch to "I." • Fill Tank. • Replace Strainer. • Clean fuel line. • Install new spark plug. • Replace spark plug. • Replace lead wire or attach to spark plug. • Contact your local authorized dealer.
3. Engine hard to start.	<ul style="list-style-type: none"> • Water in gasoline or stale fuel mixture. • Engine under or over choked. • Gasket leaks (carburetor or cylinder base gasket). • Weak spark at spark plug. 	<ul style="list-style-type: none"> • Drain entire system and refill with fresh fuel. • Drain and refill with correct mixture. • If flooded by over choking, proceed according to instructions in operation section. If under choked, move choke lever to closed position and crank two or three times. • Replace gaskets. • Contact your local authorized dealer.
4. There is black smoke coming from exhaust.	<ul style="list-style-type: none"> • The muffler screen may be clogged. • The exhaust port may be restricted. 	<ul style="list-style-type: none"> • Clean carbon from muffler screen. • Clean exhaust port.
5. Engine misses.	<ul style="list-style-type: none"> • Dirt in fuel line or carburetor. • Carburetor improperly adjusted. • Spark plug fouled, broken or incorrect gap setting. • Weak or intermittent spark at spark plug. 	<ul style="list-style-type: none"> • Remove and clean. • Clean or replace spark plug - set gap to .024-.028 in. (0.6-0.7 mm). • Contact your local authorized dealer.
6. Engine lacks power.	<ul style="list-style-type: none"> • Air filter clogged. • Carburetor out of adjustment. • Muffler clogged. • Clogged exhaust ports. • Spark Arrestor Clogged. • Poor compression. 	<ul style="list-style-type: none"> • Clean or replace air filter. • Clean carbon from muffler. • Clean Spark Arrestor. • Contact your local authorized dealer.
7. Engine overheats.	<ul style="list-style-type: none"> • Air flow obstructed. 	<ul style="list-style-type: none"> • Clean flywheel cylinder fins and screen.
8. Engine noisy or knocking.	<ul style="list-style-type: none"> • Spark plug in incorrect heat range. • Bearings, piston ring or cylinder walls are worn. 	<ul style="list-style-type: none"> • Replace with plugs specified for engine. • Contact your local authorized dealer.
9. Engine stalls under load.	<ul style="list-style-type: none"> • Engine overheats. • Carburetor adjustment too "lean." 	<ul style="list-style-type: none"> • Remove dust and dirt from between fins. • Contact your local authorized dealer.

EPA PHASE 2 / CALIFORNIA TIER III EMISSION CONTROL WARRANTY STATEMENT YOUR RIGHTS AND OBLIGATIONS

The Environmental Protection Agency (EPA) and the California Air Resources Board (C.A.R.B.) and The Equipment Manufacturer are pleased to explain the emission control system warranty on your EPA Phase 2 / C.A.R.B. Tier III model year 2005 and later small off road engine (SOREs). New small off road engines must be designed, built and equipped to meet stringent EPA and C.A.R.B. anti-smog standards. Echo, Incorporated must warrant the emission control system on your small off road engine for the periods of time listed below provided there has been no abuse, neglect or improper maintenance of your small off road engine.

Your emission control system may include parts such as the carburetor or fuel injected system, and the ignition system and catalytic converter. Also included may be hoses, belts, connectors and other emission-related assemblies.

Where a warrantable condition exists, the Manufacturer will repair your small off road engine at no cost to you including diagnosis, parts and labor.

MANUFACTURER'S WARRANTY COVERAGE:

The 1995 and later small off road engines are warranted for two years. If any emission-related part on your engine is defective, the part will be repaired or replaced by the Manufacturer.

OWNER'S WARRANTY RESPONSIBILITIES:

- As the small off road engine owner, you are responsible for the performance of the required maintenance listed in your *Operator's Manual*. The Manufacturer recommends that you retain all receipts covering maintenance on your small off road engine, but the Manufacturer cannot deny warranty solely for the lack of receipts or for your failure to ensure the performance of all scheduled maintenance.
- As the small off road engine owner, you should however be aware that the Manufacturer may deny you warranty coverage if your small off road engine or a part has failed due to abuse, neglect, improper maintenance or unapproved modifications.

You are responsible for presenting your small off road engine to the Manufacturer's authorized service center as soon as a problem exists. The warranty repairs should be completed in a reasonable amount of time, not to exceed 30 days.

If you have any questions regarding your warranty rights and responsibilities, you should contact your Product Manufacturer.

EPA PHASE 2 / CALIFORNIA TIER III EMISSIONS DEFECT WARRANTY EXPLANATION

This is additional detailed information about the EPA PHASE 2/ CALIFORNIA TIER III EMISSIONS DEFECT WARRANTY for your small off road engine.

WHAT DOES THIS WARRANTY COVER?

The Manufacturer warrants that your unit was designed, built and equipped to conform with applicable California emissions standards and that your unit is free from defects in material and workmanship that would cause it to fail to conform with applicable requirements within five (5) years. *The warranty period begins on the date the product is delivered to a retail purchaser.* This is your emission control system, DEFECTS WARRANTY.

HOW WILL A COVERED PART BE CORRECTED?

If there is a defect in a part covered by this warranty, a Manufacturer's Authorized Service Dealer will correct the defect.

You will not have to pay anything to have the part adjusted, repaired or replaced. This includes any labor and diagnosis for warranted repairs performed by the dealer. *In addition, engine parts not expressly covered under this warranty but whose failure is a result of a failure of a covered part will be warranted.*

Emissions System repairs covered under this warranty should be completed in a reasonable time, not to exceed 30 days.

IMPORTANT

If the diagnosis reveals no defect, the emission defect warranty does not apply.

WHAT PARTS ARE COVERED BY THE EPA PHASE 2/ CALIFORNIA TIER III 2005 & LATER SMALL OFF ROAD ENGINE EMISSIONS DEFECT WARRANTY?

- Any emission related part not scheduled for, "required maintenance" (See Engine Operators Manual, "SERVICE MAINTENANCE SCHEDULE") will be repaired or replaced within the warranty period. The repaired or replaced part will be warranted for the remaining Emissions Defect warranty period.
- Any emission related part scheduled for replacement during "required maintenance" (See Engine Operators Manual, "SERVICE MAINTENANCE SCHEDULE") is warranted for the period of time prior to the first scheduled replacement point for that part. Any such part repaired or replaced under warranty shall be warranted for the remainder of the period prior to the first scheduled replacement point for that part.
- Any manufacturer-approved replacement part may be used in the performance of any warranty maintenance or repairs on emission-related parts, and must be provided without charge if the part is still under warranty.
- Any replacement part that is equivalent in performance and durability may be used in non-warranty maintenance or repairs, and shall not reduce the warranty obligations of the manufacturer.
- *The owner is responsible for the performance of the required maintenance described in the operators manual.*

SPECIFIC EMISSION RELATED WARRANTED PARTS:

- Choke
- Carburetor (complete assembly or replaceable components)
- Fuel Injection Assembly or replaceable components
- Air Filter
- Electronic Ignition System
- Spark Plug
- Catalytic Converter / Muffler Assembly

WHAT IS NOT COVERED BY THE EPA PHASE 2/CALIFORNIA TIER III 2005 & LATER SMALL OFF ROAD ENGINE EMISSIONS DEFECT WARRANTY?

- *Any failure caused by abuse, neglect, improper maintenance.*
- *Any failure caused by unapproved modifications, use of unapproved add-on parts/modified parts or unapproved accessories.*



LIMITED WARRANTY

MANTIS extends this limited warranty against defects in material and workmanship for a period of five (2) years under normal usage for residential purposes and two (2) years under normal usage for commercial purposes, from the date of purchase by the original purchaser.

MANTIS will repair or replace, at its option, any part or parts of the product found to be defective in material or workmanship during the warranty period. Warranty repairs and replacements will be made without charge for parts or labor. All parts replaced under warranty will be considered as part of the original product, and any warranty on the replaced parts will expire coincident with the original product warranty. If you think your MANTIS TILLER is defective in material or workmanship, please contact customer service at 800-366-6268 for the location of an authorized servicing dealer or repair center. You will be responsible for pickup and delivery charges.

If your tiller has a [Honda] engine, this limited warranty does not cover the [Honda] engine which is warranted separately by the engine manufacturer.

MANTIS assumes no responsibility in the event that the product was not assembled or used in compliance with any assembly, care, safety, or operating instructions contained in the Operators Manual or accompanying the product. This limited warranty does not cover damages or defects due to normal wear and tear, lack of reasonable and proper maintenance, failure to follow operating instructions or operators manual, misuse, lack of proper storage or accidents. This limited warranty shall not be effective if your Mantis tiller has been subjected to negligence or has been repaired or altered by anyone other than an authorized dealer or authorized service center.

You must maintain your MANTIS TILLER by following the maintenance procedures described in the operators manual. Such routine maintenance, whether performed by you or a dealer, is at your expense.

MANTIS MAKES NO EXPRESS OR IMPLIED WARRANTIES, REPRESENTATIONS OR PROMISES EXCEPT THOSE CONTAINED HEREIN. THERE ARE NO OTHER WARRANTIES, INCLUDING WARRANTIES OF MERCHANTABILITY AND FITNESS FOR A PARTICULAR PURPOSE. ALL WARRANTIES OTHER THAN THE EXPRESS WARRANTY SET FORTH ABOVE ARE SPECIFICALLY DISCLAIMED. THE DURATION OF ANY IMPLIED WARRANTY, INCLUDING MERCHANTABILITY AND FITNESS FOR A PARTICULAR PURPOSE, IS LIMITED TO THE DURATION OF THIS WRITTEN LIMITED WARRANTY. MANTIS DISCLAIMS ALL LIABILITY FOR INDIRECT, INCIDENTAL AND/OR CONSEQUENTIAL DAMAGES IN CONNECTION WITH THE USE OF THE MANTIS PRODUCTS COVERED BY THIS WARRANTY. SOME STATES DO NOT ALLOW LIMITATIONS ON HOW LONG AN IMPLIED WARRANTY LASTS AND/OR DO NOT ALLOW THE EXCLUSION OR LIMITATION OF INCIDENTAL OR CONSEQUENTIAL DAMAGES, SO THAT ABOVE LIMITATIONS AND EXCLUSIONS MAY NOT APPLY TO YOU. THIS WARRANTY GIVES YOU SPECIFIC LEGAL RIGHTS, AND YOU MAY ALSO HAVE OTHER RIGHTS WHICH VARY FROM STATES TO STATE.

MANTIS
1028 Street Road
Southampton, PA 18966
(215) 355-9700

Specifications, descriptions, and illustrative material in this literature are as accurate as known at the time of publication, but are subject to change without notice.